

DELSTAR

HD BRUSHLESS | SERIES 171

100-17113,-D

14 Volts 250 Amps

PRODUCT SPECIFICATIONS

Part number	100-17113
System Voltage	12V
Rated Output	250A
Output @ 2000 rpm	145A
Ground	Negative
Mounting	Pad
Rotation	Bidirectional
Temperature limits:	
Low	-40°C / -40°F
High	125°C / 257°F
Speed limits:	8000 RPM continuous 9000 RPM intermittent
Coating	Corrosion-Resistant E-Coated
Weight	38 Lbs / 17.4 Kg.
Regulator	Integral
Excitation	Self-excited
Indicator Light	Yes
Remote Sense	Yes
Soft Start Delay (SSD)	Yes
Load Response Control (LRC)	Yes
Field Short Circuit Protection	Yes
Load Dump Protection	Yes
Overvoltage Shut-Down (OSD)	Yes

RECOMMENDED FOR:

- School & Shuttle Buses
- Utility Vehicles
- Marine & Mining
- Agricultural
- Construction & Industrial



100-17113



100-17113-D
with air intake cover

NOTE:

This DelStar 100-17113 alternator, meets the marine requirements for Ignition Protection on gas or diesel engines of ISO 8846, USCG, stated in Title 33 CFR 183.410, SAE J1171 and International CE Standards.

PERFORMANCE CURVES

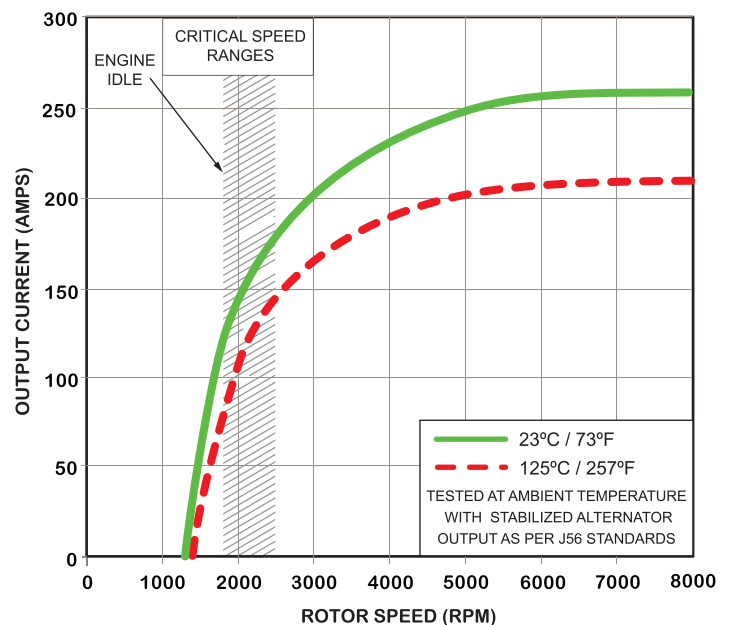

DELSTAR

HD BRUSHLESS | SERIES 171

OUTLINE

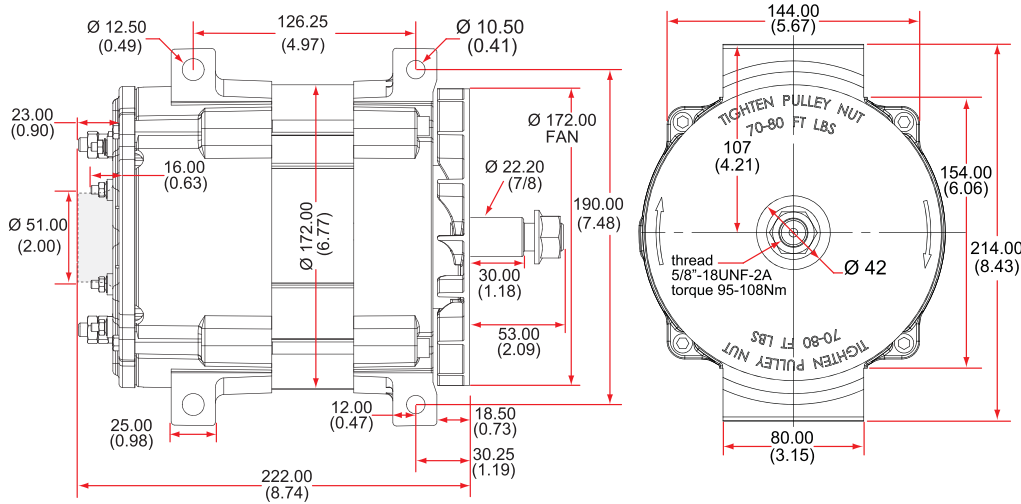

Dimensions are listed in mm over (in)

CONNECTIONS

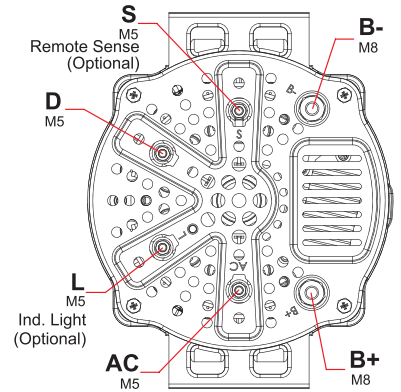

100-17113

14 Volts 250 Amps

ELECTRICAL SCHEMATIC

